



Fond du Lac Optimist Club

(Fond du Lac's First Optimist Club)

Wisconsin – Upper Michigan District – Club Number 09070



2005

Dear Parent or Guardian,

Once again the Fond du Lac Evening Optimist Club is sponsoring the **ANNUAL TRI-STAR BASKETBALL SKILLS CONTEST** for youth in the City of Fond du Lac and neighboring communities. **AS ALWAYS**, this is a **Completely Free Competition**.

The local competition will be held in **Fond du Lac at Elizabeth Waters Elementary School Gymnasium**. The doors will open at **9:00am** and competition will begin at **10:00am** on **SATURDAY, MARCH 19, 2005**.

The competition will test the following basketball skills: shooting, passing and dribbling. Individual girls and boys (ages 8 through 13) are eligible. An entry form is attached to this letter. **ADDITIONAL ENTRY FORMS WILL BE AVAILABLE AT LOCAL SCHOOLS AND AT WATERS SCHOOL THE MORNING OF THE COMPETITION**, or can be downloaded from www.fdl.net/optimist. Each youth that intends to participate in the local competition must have a completed **ENTRY FORM** with **PARENTS AUTHORIZATION** OR THEY WILL NOT BE ALLOWED TO COMPETE.

The twelve (12) first place winners (6 girls and 6 boys) will be eligible to represent the Fond du Lac Evening Optimist Club in the regional competition against youth representing other Optimist Clubs from around the state. The date of the regional competition is **APRIL 2, 2005** (doors open at **9:00am**, competition at **10:00am**) at **Marian College Sadoff Gymnasium**. Each participant representing our Optimist Club at the regional competition will receive a Fond du Lac Evening Optimist T-shirt and will compete **for trophies** (1st through 3rd place) and a **basketball for the 1st place finisher**. All other participants will receive participation ribbons.

We are looking forward to being able to provide this competition for the youth of the Fond du Lac area and encourage you to make this opportunity available to your son or daughter. We are usually finished with the local competition by 12:00 noon.

If you need additional information, please feel free to contact me at (920) 921-6586.

Tom Scannell
N8215 Billene Dr
Malone, WI 53049
(920) 921-6586

Post Office Box 1422 Fond du Lac, WI 54936-1422

Optimist Tri-Star Basketball

CHECKONE

Boy ___ Girl ___

Entry Form and Instructions

Age (circle One) 8 9 10 11 12 13

Name _____ Telephone (_____) _____

Address _____

School Name _____ Date of Birth ____/____/____

How old will you be on March 15th? _____

Parent's Permission _____ Parents are welcome at the contest

- Participants may compete in only one local contest
- Participants will compete against others of the same age as of March 15th
- Gym shoes will be required
- Decisions of the judges will be final

Contest Information Place _____

Date: ____/____/____ Time: _____

Dribbling Skill

Each of the participants will attempt to dribble through four cones and return through the course as quickly as possible. Three points will be deducted from a base score of 75 points for each second of elapsed time. For example, if a participant takes 20 seconds to complete the course, the participants score is 15. $(75 - (3 \times 20) = 15$.

Number of seconds elapsed = x $75 - (3x)$ = score

TIME _____

SCORE _____

Passing Skill

Each participant will be allowed six attempts; three bounces and three chest or overhead passes at a designated target from an assigned distance. Participant will be allowed one step toward passing line and must not touch or go over it.

Distance from Target: **AGE 8-9 / 12'** **AGE 10-11 / 13'** **AGE 12-13 / 18'**

3 DIRECT PASSES _____ 3 DIRECT BOUNCE PASSES _____

5 points each time a target is hit = SCORE _____

Shooting Skill

Each participant will be allowed six attempts; four free throw attempts at varying distance according to age, and two attempts from anywhere on the court outside of the key area. Attempt will be invalidated if a participant steps on or over the assigned free throw line.

Distance from Basket: **AGE 8-9 / 11'** **AGE 10-11 / 12'** **AGE 12-13 / 15'**

4 FREE THROWS _____ 2 OTHER THROWS _____

10 points each basket made = SCORE _____

TOTAL SCORE (three events) _____

For additional forms, please photocopy

DRIBBLING SKILL

Each contestant must dribble through a prescribed course of four obstacles laid out in a straight line, weaving in and out of the obstacles, circling the last one and returning through the course in the same fashion. The course is 32' long, with the obstacles 8' apart. Each contestant starts with 75 points and three points are deducted for each second of elapsed time.

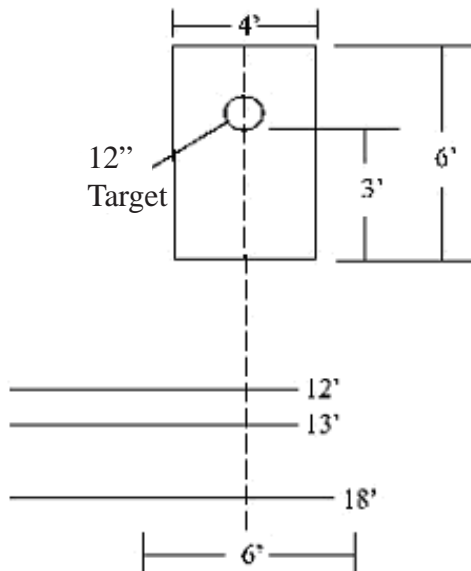
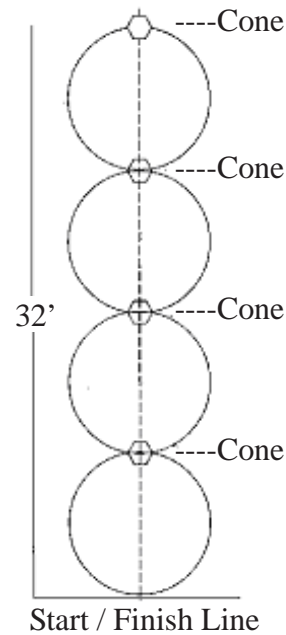

PASSING SKILL

Each contestant will have three direct passes and three bounce passes at the target. Contestants age 8 & 9 will pass from the 12' mark; age 10 & 11 will pass from the 13' mark; and age 12 & 13 will pass from the 18' mark. Five points will be awarded for each pass in which the ball touches the target; NO POINTS will be awarded if the ball does not touch the target. Perfect score is 30 points. Target is a 12" circle, 1 1/2 inch thick, and mounted on a sheet of 3/4" x 4' x 6' plywood.

SHOOTING SKILL

Each contestant will have 6 shots; 4 free throws at varying distances according to age, and 2 shots from anywhere on the court outside the key area. Free throws for contestants 8 & 9 will be from 11' from the backboard; contestants 10 & 11 will be from 12' from the backboard, and contestants 12 & 13 will use the regular free throw line, which is 15' from the backboard. Each basket made is scored 10 points. Perfect score – 60 points. Shot is invalidated if contestant steps over or on the assigned free throw line.

